

Accu-Therm[®] Plate Heat Exchangers

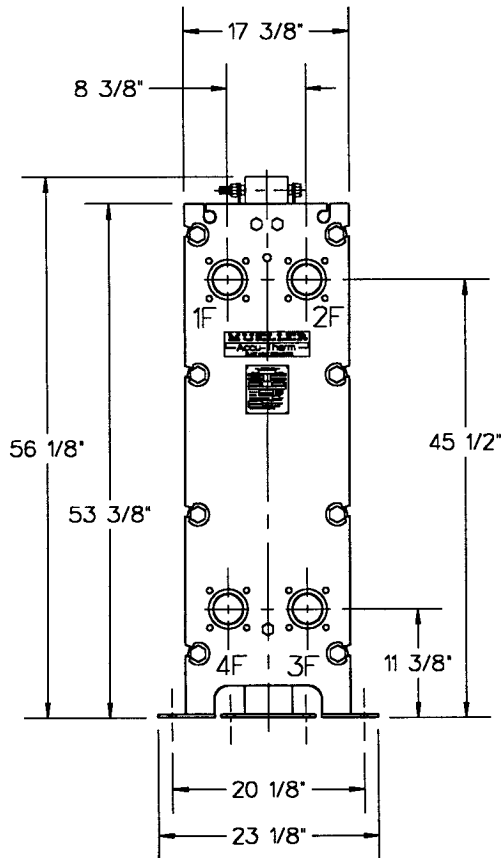

FRONT VIEW

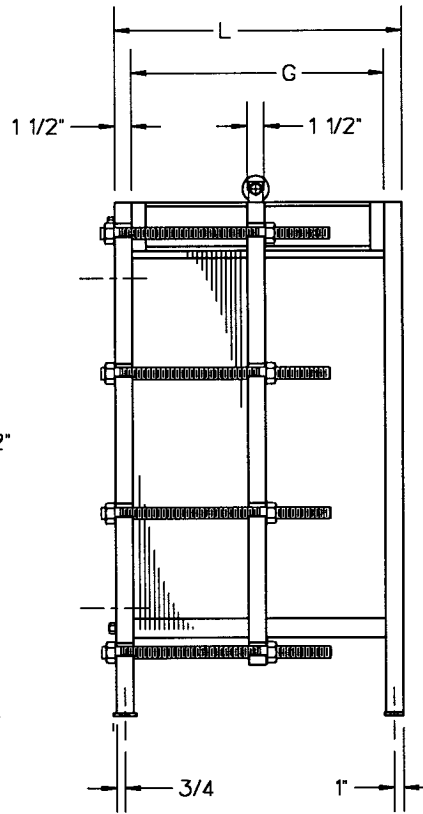

SIDE VIEW

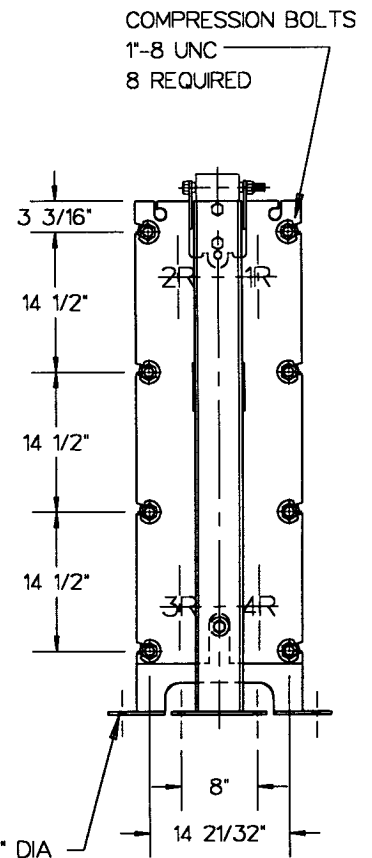

REAR VIEW

COMPRESSION BOLTS
1"-8 UNC
8 REQUIRED

PORT
LOCATIONS

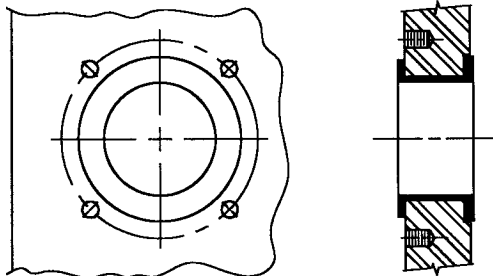
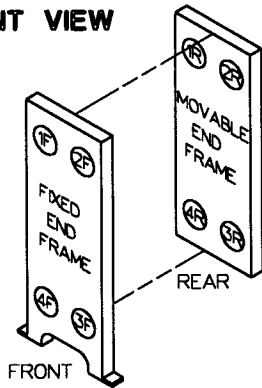

STANDARD CONNECTION
STANDARD 2 1/2" STUDDED PORT
(REFER TO REVERSE SIDE FOR ADDITIONAL
CONNECTION DETAILS.)

STANDARD MATERIALS OF CONSTRUCTION

End frames SA-515-70, SA-516-70, or equivalent
Plate hanger Type 304 stainless steel
Compression bolts (zinc plated) SA-193-B7
Compression nuts (zinc plated) SA-194-2H
Connection studs (zinc plated) (optional).....SA-193-B7
Connection nuts (zinc plated) (optional).....SA-193-2H
Shroud (optional) Type 304 stainless steel
Paint Corrosion-resistant paint

Refer to computer printout for variable dimensions and complete plate, gasket, and connection specifications.

MUELLER[®]

**MODEL AT20
FRAME TYPE B-20**

FLANGED CONNECTIONS

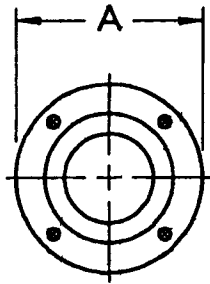

FRONT VIEW

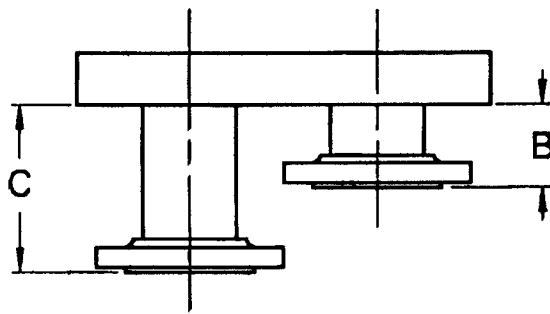

TOP VIEW

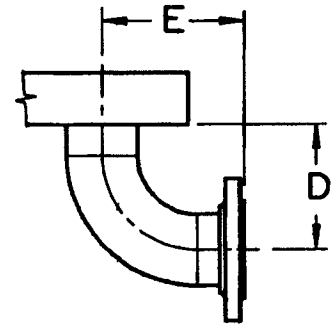

TOP VIEW

Connection	Size	A	B	C	D	E	No. Bolts/Conn.	Bolt Size
Studded port	2 1/2"	7"	—	—	—	—	4	5/8"-11 UNC
Lap-joint flange	2"	6"	4"	—	—	—	4	5/8"-11 UNC
	2 1/2"	7"	4"	—	—	—	4	5/8"-11 UNC
	3"	7 1/2"	4"	—	—	—	4	5/8"-11 UNC
Lap joint with elbow	2"	6"	—	—	7 5/16"	9"	4	5/8"-11 UNC
	2 1/2"	7"	—	—	5 3/4"	6 3/4"	4	5/8"-11 UNC
	3"	7 1/2"	—	—	6 1/2"	7 1/2"	4	5/8"-11 UNC

NOTE: 1. Adjacent flange faces must be offset in some cases. Flanges located at Port Positions 1 and 4 are extended to "C" dimension when offset is required.
 2. If connections are other than the standard connection (shown on front), or if the unit is a multipass, contact Paul Mueller Company for clarification.

PLATE CAPACITY / GUIDE LENGTH

Guide length (DM G)	30"	48"	66"	84"	102"	120"	138"	156"
Frame length (DM L)	33 3/8"	51 3/8"	69 3/8"	87 3/8"	105 3/8"	123 3/8"	141 3/8"	159 3/8"
Plate cap. AT20 H/V 0.6 mm	84	173	261	349	437	525	613	701
Plate cap. AT20 lock-in H/V 0.6 mm	86	174	263	352	440	529	617	706
Plate cap. AT20 lock-in H/V 0.5 mm	88	179	269	360	450	541	631	722
Plate cap. AT20P H/V 0.5 mm	96	196	295	394	494	593	692	791

PLATE CAPACITY / COMPRESSION-BOLT LENGTH

Compression-bolt length	12"	18"	24"	36"	48"	60"	78"	96"	114"	132"
Plate cap. AT20 H/V 0.6 mm	29	59	88	147	206	264	353	441	529	617
Plate cap. AT20 lock-in H/V 0.6 mm	30	60	89	148	207	266	354	443	531	620
Plate cap. AT20 lock-in H/V 0.5 mm	30	60	90	151	211	272	362	453	544	634
Plate cap. AT20P H/V 0.5mm	33	66	99	165	232	298	397	496	596	695

Paul Mueller Company

P.O. Box 828 • Springfield, MO 65801-0828

Telephone: (417) 831-3000 • 1-800-MUELLER

Fax: (417) 831-6642